



Mercedes-Benz

600



*"The
Mercedes-Benz 600
proved
to our complete
satisfaction
that it is
the best car
in the world."*





Mercedes-Benz 600

The reputation of 'The Grand Mercedes' in the international circle of exclusive cars rests upon its technical conception, its performance and its equipment. Its refinement, advanced design, safety and extraordinary comfort have no equal. In its exterior styling it avoids unnecessary ornamentation and passing fashions in order to achieve a timeless elegance.

Two basic types of the Mercedes-Benz 600 are available: the 5-6 seat Sedan, with a wheelbase of 126" (3,200 mm), which can be supplied with a central division; and the Seven Passenger Limousine, wheelbase 153.3" (3,900 mm), with central division and a choice of either four doors with two backward-facing seats in the rear, or six doors with two forward-facing folding seats in the rear. The two latter choices are offered principally to meet the needs of heads of state, industry and other people of eminence having considerable public responsibilities.

'The Grand Mercedes' demonstrates to the world the enterprise of Daimler-Benz AG and their unparalleled achievements in modern automobile engineering.

The Interior

In designing 'The Grand Mercedes', Daimler-Benz laid down certain guiding principles; a very high standard of comfort for both driver and passengers with generous space, the best possible suspension, individual seat-adjustment, infinitely variable ventilation, heating and - when desired - air conditioning, silence, and the virtual elimination of manual effort. Every means of achieving a high standard of comfort has been employed.

In addition to the comprehensive, high quality appointments, there is a push-button, hydraulically powered system controlling most manual functions. In the photograph, the interior of the 5-6 seat Sedan is shown. The two anatomically shaped seats, each with folding center armrest, are fully adjustable by means of the push-button hydraulic controls. Moreover, the driver can adjust the position of the steering wheel to his individual requirements.



Commenting on this, the Swiss journal "Automobile Revue" wrote: "Thus the driver enjoys the benefits of made-to-measure seating, resulting in relaxed and complete control of the car."

The unobtrusive and clearly laid-out instrument panel matches the standard of the interior appointments. The use of rare wood, fine leather and velours upholstery fabrics contribute to the atmosphere of comfort and elegance.

In the rear there is a spacious bench-seat with a folding armrest and also headrests.

As with the front seats, its position is controlled at the touch of a button. It can be adjusted from an upright to a reclining position automatically.

The opening and closing of windows, too, is operated by push-button control, ensuring effortless, silent movement. These controls can, of course, be operated at the wish of either the driver or passengers. To ensure freedom from mist or icing, the rear window incorporates electrical heating elements. And to avoid dazzling sunshine or headlights, the rear window and adjacent side windows are fitted with curtains. The central dividing screen can be raised or lowered



hydraulically by either the driver or passengers. The optional sliding roof is controlled in the same manner. Heating, ventilation, air-flow and the optional air-conditioning merely require the setting of a selector by the driver. The temperature is thereafter maintained at the required level automatically. In hot weather, additional ventilation is provided by a booster fan.



The rear of the 5-6 seat
Sedan with central partition



Rear of the 6-door
Limousine with folding seats

Rear of the Limousine with facing seats

Ample space for your luggage



The carpeted trunk has been designed for the safe storage of large luggage loads. The spare wheel is accommodated in a separate, closed compartment. After the loosening of a wheel retaining nut, removal of the wheel is spring assisted.



A set of special suitcases, consisting of 3 large cases, 2 medium ones, a hatbox and one week-end case, can be supplied.

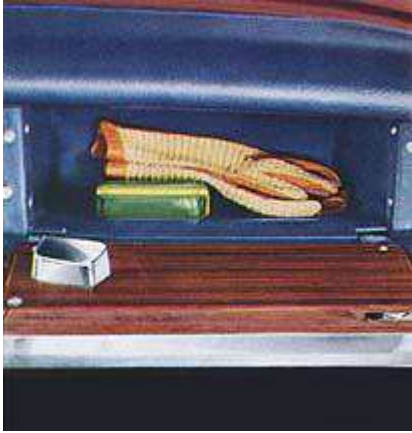

The spacious lockable glove box on the front passenger side is illuminated. On opening, a map reading lamp on the underside of the lid switches on.



The additional central shelf under the dash-board provides further space for oddments.



The cocktail cabinet in the partition of the 5-6 seat Sedan, with shelf above. To the right and left of this, a folding table with glare-free lighting.



In the 6-door Limousine with folding seats the center partition has an additional shelf on both sides.

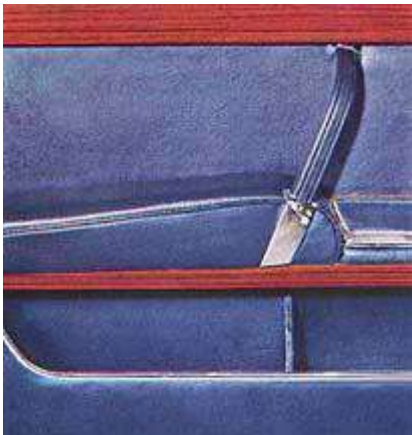

For personal requisites within easy reach at all times, there are generous leather covered door pockets.



In the Seven Passenger Limousine, with facing rear seats, the cabinet is located between the two single seats, the door serving as a table.

Safety and Comfort

'The Grand Mercedes' combines the traditional Mercedes qualities of high performance, safety and comfort, to a higher degree than any other fine car. Leading test drivers have acclaimed it in the following words: "We spoke of the sportscar-like driving characteristics of 'The Grand Mercedes'. In fact, many sportscar manufacturers would be more than pleased if their cars could take corners as fast, effortlessly and safely..." The superb ride and road holding of the Mercedes-Benz 600 are the result of long experience and the development of a very advanced suspension system. The principles of the design of this suspension have been proved and convincingly demonstrated in the Mercedes-Benz 300 SE.



The Daimler-Benz 4-speed automatic transmission fitted to 'The Grand Mercedes' changes gears quickly, smoothly and always at the correct speed. An over-ride selector on the steering column allows the driver to revert to manual gear changes whenever he wishes. Effortless control when manoeuvring, parking, or turning at low speed, is achieved through the use of Daimler-Benz power-assisted steering. Yet the steering always retains the sense of "feel" essential to safe driving at speed. A twin-circuit servo-assisted brake system, with discs all round, ensures absolutely safe, dependable stopping power.

Two brake calipers operate on each of the front discs. Air-suspension gives 'The Grand Mercedes' outstanding ride comfort and maintains the car at a constant height, irrespective of load. The road clearance can be adjusted while moving to suit different surface conditions. Shock-absorbers, fitted close to the wheels, are adjustable to ensure the greatest comfort at all times.

A differential lock automatically compensates for any variations in the road adhesion of the right and left rear wheels. This ensures balanced power transmission through both rear wheels at all times. In designing the power unit for the Mercedes-Benz 600 our engineers had to fulfill a long list of requirements. First there must be ample power in reserve to give the car outstanding acceleration ability, "power to spare" to provide for the operation of the hydraulic equipment and to ensure silence and flexibility at all engine speeds. Compactness and low weight were additional considerations which had to be weighed. It was decided to use an 8-cylinder overhead camshaft V engine of 6,329 ccm to meet these requirements. An 8 plunger fuel injector pump was specially designed so that the well proved induction pipe fuel injection system could be incorporated. The radiator fan is engaged by a thermostatically controlled hydraulic clutch.

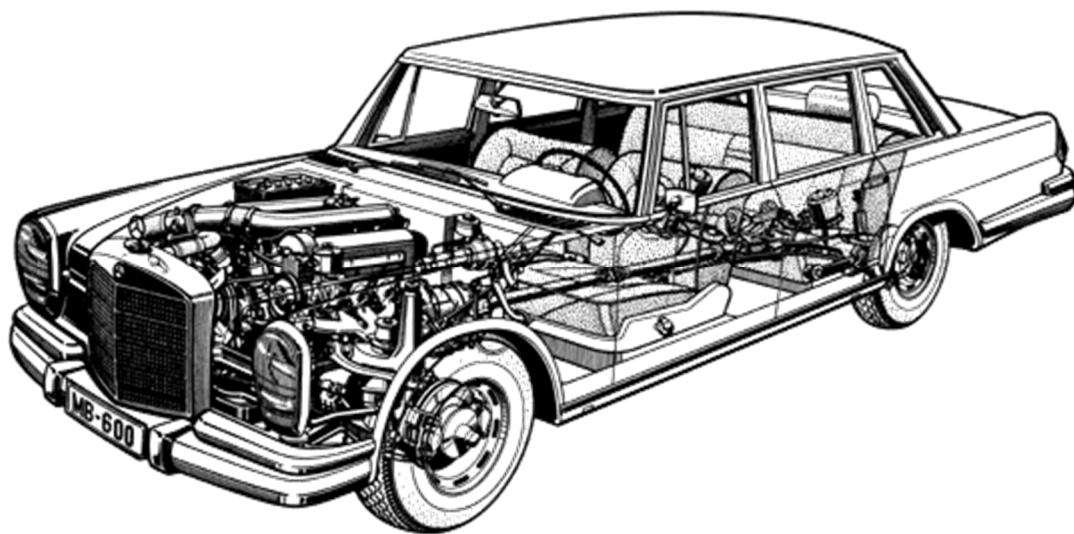
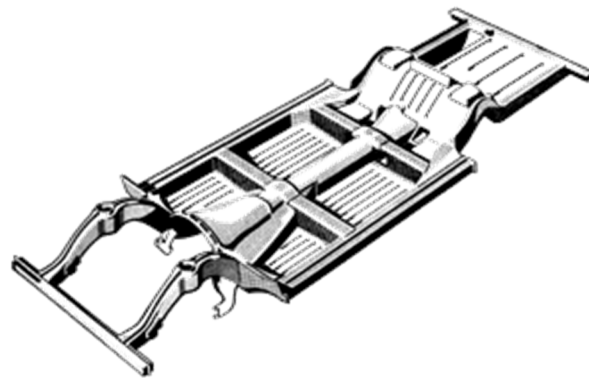
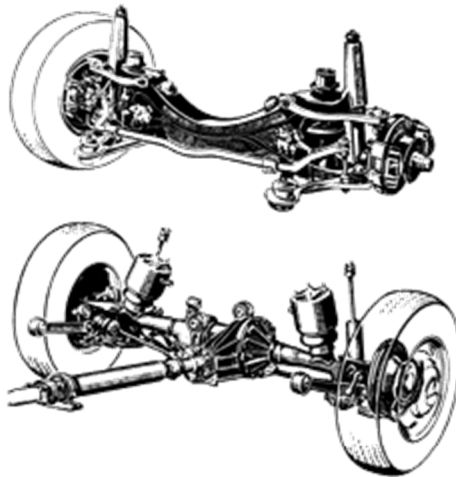

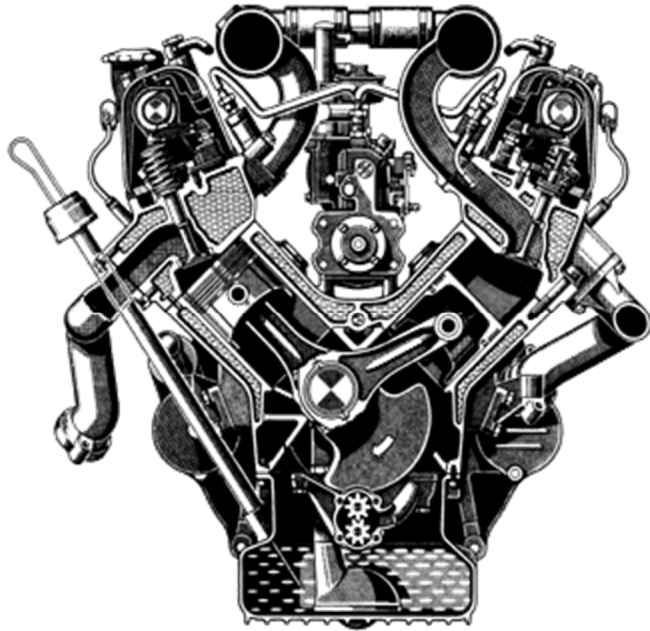

With this description, we have given you some idea of the characteristics of 'The Grand Mercedes' and its many technical features. All are the result of continuous development, culminating in a car that takes its place in the forefront of achievement in automobile engineering. 'The Grand Mercedes' epitomises progress to date, and in pointing the way to an even greater future for the automobile, sets new standards against which all other cars should be matched.





Command and Control

Heating, ventilation, air-flow and the optional air-conditioning merely require the setting of a selector by the driver. The temperature is thereafter maintained at the required level automatically. In hot weather, additional ventilation is provided by a booster fan.

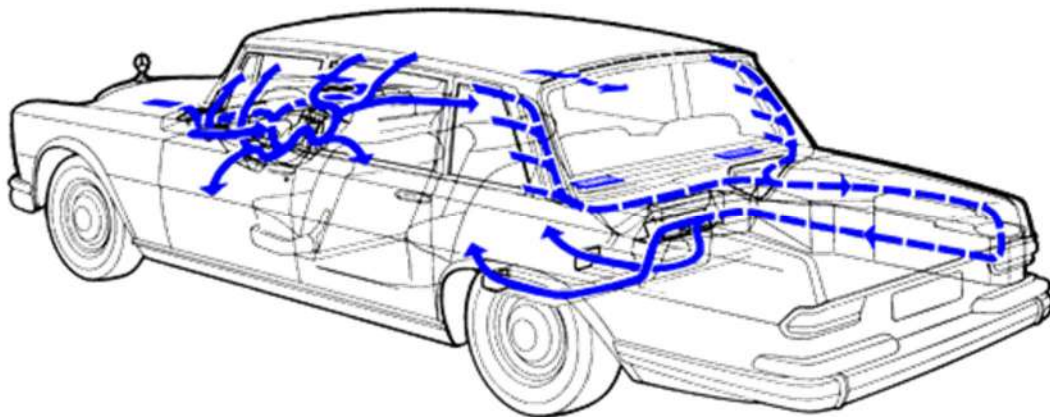



In the 5-6 seat Sedan without central partition, both front seats are fully adjustable horizontally and vertically by a single button. The same button adjusts the angle of the backs of these seats down to the horizontal. In limousines with central partition, the horizontal front seat adjustment is hand operated.



To ensure the comfort of both tall and short drivers the position of the steering wheel can be adjusted after turning the padded wheel boss.



The rear seat is hydraulically adjustable. The seat can be moved forward and the reclining back adjusted to the desired angle.



A lever on the steering column adjusts the shock absorbers to meet the variations in different road surfaces.

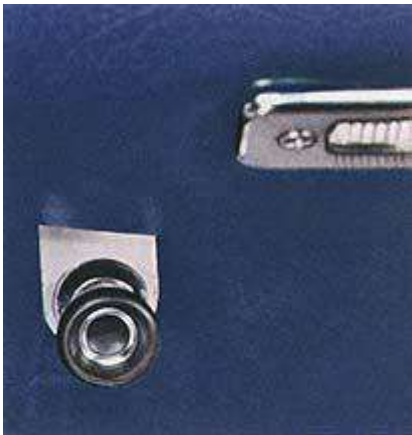

With this pull button, road clearance can be increased while driving by 2.0" (50 mm), when required.



A selector on the dashboard governs the heating, ventilation and air flow (air conditioning is optional). Louvers on the air-intake grill in front permit directional control of the air stream.



The parking brake is foot operated. When driving off from standstill, this brake is released automatically. It can also be released by means of a small hand lever.

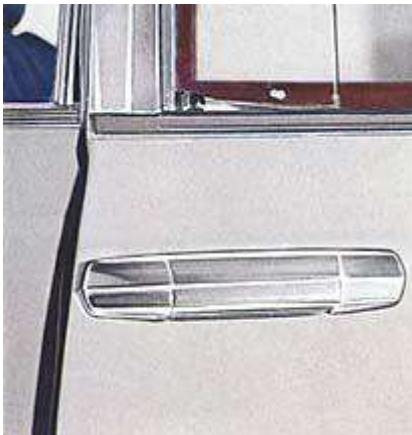

The lightest touch is sufficient to close the doors silently. They are hydraulically assisted and close securely. Locking the driver's door automatically locks all doors, the trunk lid and the filler cap.

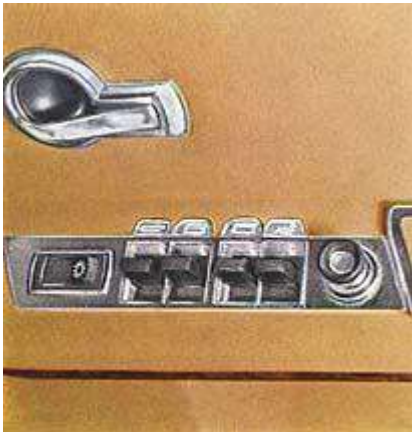

The illustration shows one of the control panels of the hydraulic push-button system. Unlike the more widely used electrically operated systems, the hydraulic system has the advantage of greater reliability and safety. In addition, its operation is completely silent.

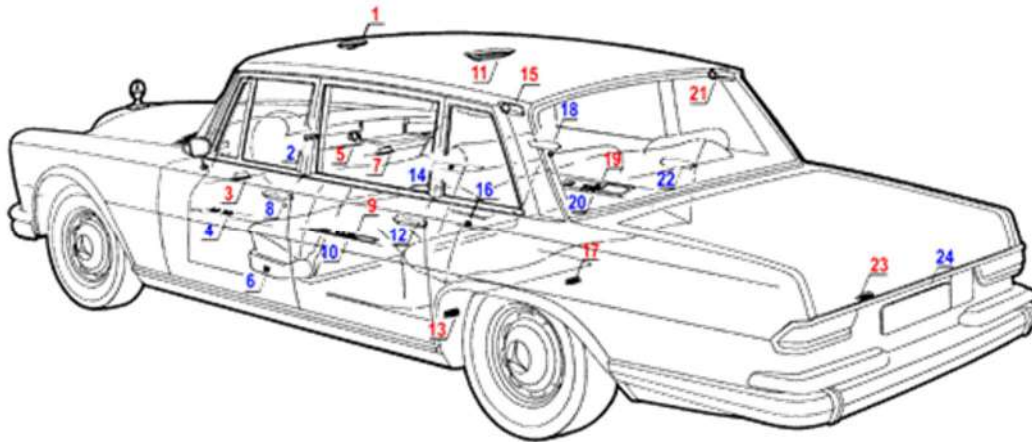

Lighting	Press-button system
<p>1 Courtesy light and map reading light either door operated or by switch on the lamp.</p> <p>3 Foot-well light at front left-hand side.</p> <p>5 Glove box light.</p> <p>7 Foot-well light at right.</p> <p>9 Light for push-button cigar lighter and ashtray in left rear door.</p> <p>11 Roof light.</p> <p>13 Foot-well light rear left.</p> <p>15 Reading lamp, rear left.</p> <p>17 Door-operated foot-well light, rear right.</p> <p>19 Light for push-button cigar lighter and ashtray in right rear door.</p> <p>21 Adjustable reading light, rear right.</p> <p>23 Trunk light.</p>	<p>2 Automatically operated sliding roof and glass screen in center partition.</p> <p>4 Front window left, front window right, rear window left, rear window right.</p> <p>6 Driving seat adjustment.</p> <p>8 Front left door lock. Control locking device for all doors</p> <p>10 Glass screen central partition; left rear window; rear seat adjustment.</p> <p>12 Lock of left rear door.</p> <p>14 Front right window.</p> <p>16 Front right seat adjustment.</p> <p>18 Front right door lock.</p> <p>20 Sliding roof, right rear window, rear seat adjustment.</p> <p>22 Right rear door lock.</p> <p>24 Trunk lid lock.</p>

The door operated interior lights switch off approximately 10 seconds after the doors are closed.

'The Grand Mercedes'

Future discussions on cars in the most sophisticated circles will inevitably include 'The Grand Mercedes'. Its appearance, equipment and performance clearly express the high position the Mercedes-Benz 600 has been destined to occupy. In the first place, it meets the exacting demands involved in meeting the requirements of men in leading positions. At political, commercial, scientific and cultural events in all parts of the world, 'The Grand Mercedes' will bear witness to the progressive thinking of Daimler-Benz and the high standard achieved in modern Automobile engineering. This distinctive character is shared by the 5/6 seater saloon which can be supplied with central division and the Pullman limousine 7/8 seater with 3 row

seating and central division as part of its standard equipment. Special features of the equipment. Hydraulic press button operation for adjusting front seats and seatbacks, opening and closing of windows, the glass screen behind the front seats, the sliding roof, bonnet and boot lid and for closing the doors. Other interesting details: the central locking system for all 4 doors, the boot and fuel tank-filler cap: two external rear view mirrors adjustable from inside the car, extensive interior lighting, separate heating and ventilating system for front and rear compartment with air conditioning as an optional extra. Technical features of special interest: 6.3 litre V 8 engine with intermittent inlet port fuel-injection and overhead camshaft, DB automatic transmission, DB power steering, air suspension with adjustable ground clearance, adjustable shock absorbers, hydraulic servo assisted disc brakes on all wheels with duplicated brake lines, limited slip differential.

With this brief description we have tried to give you an idea of the general conception and the many special features of this car. They are the result of continuous development which has culminated in the Mercedes-Benz 600.

Out of the greatness of the past 'The Grand Mercedes' points towards the even greater future of the automobile.



Specification

Wheel base	126 ins. = 3200 mm
Pullman limousine	153.5 ins. = 3900 mm
Overall length	218 ins. = 5540 mm
Pullman limousine	246 ins. = 6240 mm
Steering wheel rim to backrest of driving seat	13.4 ins. = 340 mm
Seat to roof	38.4 ins. = 975 mm
Rear of driving seat back to rear seat back	37.8 ins. = 960 mm

Rear seat to roof	34.9 ins. = 885 mm
Width measured at level of window key	
front	61.8 ins. = 1570 mm
rear	60.4 ins. = 1535 mm
Overall width	87.0 ins. = 1950 mm
Track front	62.35 ins. = 1587 mm
Track rear	62.05 ins. = 1575 mm
Useable luggage space with one spare wheel	20.5 cu. ft. = 0.58 m ³
Road Clearance min./max. approx.	8/10 ins. = 200/250 mm
Turning circle	40.7ft. = 12.4 m
Pullman limousine	47.8 ft. = 14.6 m
Cylinders	8
Bore/stroke	4.06/3.74 ins. = 103/95 mm
Swept volume	386.26 cu. ins. = 6.329 cm ³
Power output SAE	300 gr. HP at 4100 r.p.m.
Power output DIN	250 HP at 4000 r.p.m.
Max. torque SAE	434 ft. lbs. = 60 mkg at 3000 r.p.m.
Max. torque DIN	369 ft. lbs. = 51 mkg at 2800 r.p.m.
Maximum engine speed	4800 r.p.m.
Compression ratio	9:1
Maximum speed approx	128 m.p.h. = 205 km/h
Tank capacity	24.6/29.6 Imp/US galls. = 112 ltr.
Reserve	2.2/ 2.6 Imp/US galls. = 10 ltr.
Fuel recommended:	Super grades
Transmission:	DB automatic four-speed with hydraulic clutch and selector on the steering column.
Final drive ratio	1:3.23
Braking system:	Twin-circuit booster brake system with disc brakes on all wheels, twin brake calipers at front.
Steering:	DB power steering with automatic adjustment for wear and steering damper. Steering wheel adjustable for rake.
Rear axle:	Single-joint low-pivot swing-axle and limited slip differential
Suspension:	Self-leveling air suspension, telescopic shock absorbers adjustable while moving and torsion bar stabilisers front and rear.
Vehicle weight with spare wheel and tools	5380 lbs. = 2440 kg
Pullman limousine	5800 lbs. = 2630 kg
Permitted maximum weight	6590 lbs. = 2990 kg
Pullman limousine	7230 lbs. = 3280 kg

Specification

Engine

Cylinders 8
Bore/stroke
4.06/3.74 ins. = 103/95 mm
Swept volume
386.26 cu. ins. = 6,329 cm³
Power output SAE*
300 gr HP at 4,100 r.p.m.
Power output DIN **
250 HP at 4,000 r.p.m.
Max. torque SAE
434 ft. lbs. = 60 mkp at 3,000 r.p.m.
Max. torque DIN
369 ft. lbs. = 51 mkp at 2,800 r.p.m.
Maximum engine speed 4,800 r.p.m.
compression ratio 9:1
Engine sump capacity max./min.
12.7-9.5 pts. = 6.0-4.5 ltr.

Performance figures:

Maximum speed
approx. 125 m.p.h. = 200 km/h
Acceleration from
0-62.1 m.p.h. (100 km/h) 9.7 sec.
Tank capacity
29.6 gals. = 112 ltr.
Reserve 5.0 gals. = 19 ltr.
Fuel recommended: Super grades

Weights

Vehicle weight 5,455 lbs. = 2,470 kg
Permitted maximum weight
6,725 lbs. = 3,050 kg

Mercedes-Benz 600 Sedan (5-6 passengers)

Chassis

Transmission: DB automatic four speed with hydraulic clutch and selector on the steering column
Final drive ratio 1:3.23
Tires tubeless 9.00 H 15
Supersport Nylon
Battery 12 V/88 Ah
Two three-phase current generators
Braking system: Twin-circuit hydraulic brake system with pneumatic booster
Disc brakes on all wheels, twin brake calipers at front
Steering: DB power steering with automatic adjustment for wear and steering damper. Steering wheel adjustable for rake
Rear axle: Single-joint low-pivot swing-axle and limited slip differential
Suspension: Self-leveling air suspension, telescopic shock absorbers adjustable while moving and torsion bar stabilisers front and rear

* In measuring gross H. P. power required for auxiliaries has not been taken into account.

** The stated HP figure which does take account of power required for auxiliaries is the net power available at the clutch. The manufacturers reserve the right to change specifications and equipment without notice.

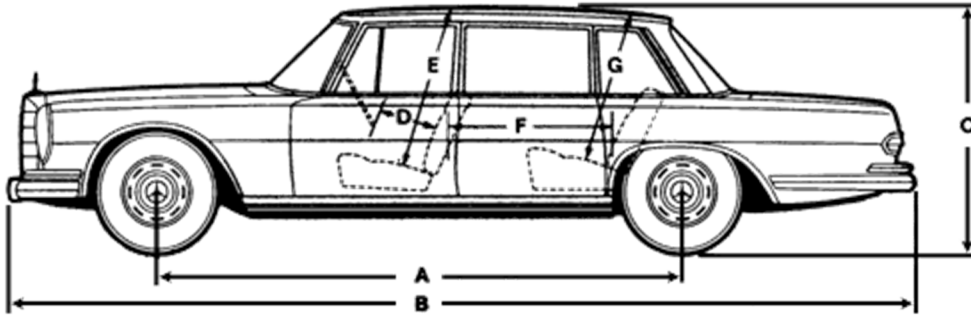

- A Wheel base 126 ins. = 3,200 mm
- B Overall length 218 ins. = 5,540 mm
- C Height 58.5 ins. = 1,485 mm + increase by 2.0 ins. = 50 mm
- D Steering wheel rim to backrest of driving seat 13.4 ins. = 340 mm
- E Seat to roof 38.2 ins. = 970 mm

- F Rear of driving seat back to rear seat back 37.8 ins. = 960 mm
- G Rear seat to roof 34.9 ins. = 885 mm
- H Width measured at level of window key front 61.8 ins. = 1,570 mm rear 60.4 ins. = 1,535 mm
- K Overall width 76.8 ins. = 1,950 mm

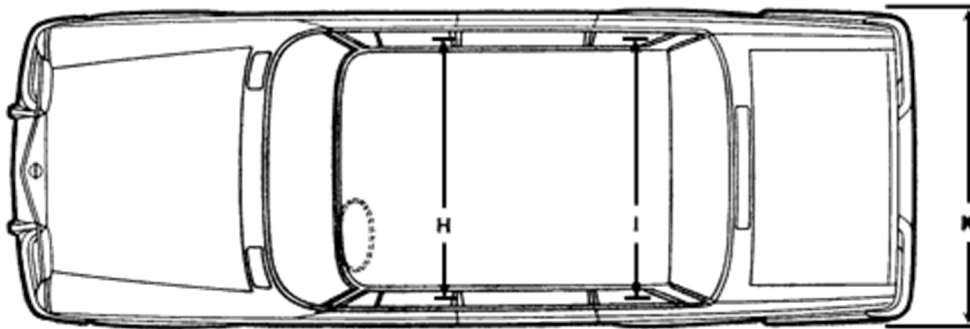

- Track front 62.53 ins. = 1,587 mm
- Track rear 62.24 ins. = 1,581 mm
- Usable luggage space 20.5 cu. ft. = 0.58 m³
- Road Clearance min./max. approx. 6/7.9 ins. = 152/200 mm
- Turning circle 40.7 ft. = 12.4 m
- Height with open hood 78.7 ins. = 2,000 mm
- Height with open trunk lid 64.6 ins. = 1,640 mm
- Width with open driver's door 112.6 ins. = 2,860 mm
- Angle of approach = 20° 30'
- Angle of departure = 9° 30'
- Ramp angle = 11° 30'

Basic Equipment

Windshield

- Windshield washers
- Two-speed wipers

Signalling equipment

- Air horn and two electric horns
- Additional high-volume horn available
- Automatic cancelling of flashing indicators

Rear Window

Rear window electrically heated

Lighting

Asymmetric dim beam

Fog lamps

Front and rear limit lights

Flashing direction indicators

Parking light

Brake lights

Back-up lights

Instrument lights dimmer-switch controlled

Socket for inspection lamp (in the engine compartment)

Light in glove box

Map-reading light

Trunk light

Foot well lights, 2 in front and 2 at rear Roof light at rear

2 adjustable reading lamps in rear roof pillars

Instruments

Speedometer

Tachometer

Indicator of selector lever position

Oil pressure gauge

Gasoline gauge

Engine thermometer

Indicator lights for battery charge, flashing indicators, headlight beam, parking brake, servo hydraulic system, air pressure, fuel reserve

Electric clock

Total-mileage recorder

Trip recorder

Outside-air thermometer

Pull button for level adjustment

Miscellaneous

Console tray between front seats

Side compartments on all 4 doors

Parcel shelf in the front over transmission tunnel

Parcel net on front seat backs

Glow-free rear-view mirror

2 exterior rear-view mirrors adjustable from the inside

2 padded sun-visors, with vanity mirror on passenger side

4 hand-rails in the roof frame

Grab-handles on all doors

4 coat-hangers in rear (2 each side)

Armrests on all doors

Locks

4 hydraulically-operated safety door-locks

Central control for locks on doors, trunk and gasoline-filler cap.

Manual operation of all door locks from the inside, and of front doors and trunk from outside

Steering lock combined with ignition switch, starter and device to prevent accidental starter operation

Lock on glove box

Hydraulic push-button system

Push-button hydraulic opening and closing of door windows

Rear seat and center arm-rest fully adjustable hydraulically by pressing a button

Front seats horizontally and vertically adjustable hydraulically by pressing a button

Front back-rest rake infinitely adjustable hydraulically down to horizontal position by pressing a button

Hydraulic adjustment of shock-absorbers by lever on the steering column

Heating and Ventilating system

Front: Heating and ventilating system with 2 heat-exchangers and blower

Rear: Heating and ventilating system with 1 heat-exchanger and blower Atmospheric pressure ventilation system

Temperature selector with electronic control to compensate for effect of different driving speeds

De-froster for side windows

De-frosting of rear window by electric heating elements embedded in the glass

Optional extras

Center partition with hydraulically-operated glass screen, bar, shelf for vanity box, and at right and left, folding table with indirect lighting

Air conditioner

Katagor glass

Steel sliding roof hydraulically operated by push-button

Intercommunication system driver-passenger compartment in limousines with center partition

Headrests on front seats

Radio with autom. aerial and remote control, short wave adapter

Set of suitcases

Independent center armrests for each of the front seats
Folding armrest in rear
2 adjustable headrests in rear
Ashtrays on all doors
Automatic cigar-lighter on all doors
Safety steering wheel adjustable for rake
2 footrests in rear
Curtains on rear window and rear side windows

Specification

Engine

Cylinders 8
Bore/stroke
4.06/3.74 ins. = 103/95 mm
Swept volume
386.26 cu. ins. = 6,329 cm³
Power output SAE*
300 gr HP at 4,100 r.p.m.
Power output DIN **
250 HP at 4,000 r.p.m.
Max. torque SAE
434 ft. lbs. = 60 mkp at 3,000 r.p.m.
Max. torque DIN
369 ft. lbs. = 51 mkp at 2,800 r.p.m.
Maximum engine speed 4,800 r.p.m.
compression ratio 9:1
Engine sump capacity max./min.
12.7-9.5 pts. = 6.0-4.5 ltr.

Performance figures:

Maximum speed
approx. 125 m.p.h. = 200 km/h
Acceleration from
0-62.1 m.p.h. (100 km/h) 9.7 sec.
Tank capacity
29.6 gals. = 112 ltr.
Reserve 5.0 gals. = 19 ltr.
Fuel recommended: Super grades

Mercedes-Benz 600 Seven Passenger Limousine

Chassis

Transmission: DB automatic four speed with hydraulic clutch and selector on the steering column
Final drive ratio 1:3.23
Tires tubeless 9.00 H 15
Supersport Nylon
Battery 12 V/88 Ah
Two three-phase current generators
Braking system: Twin-circuit hydraulic brake system with pneumatic booster
Disc brakes on all wheels, twin brake calipers at front
Steering: DB power steering with automatic adjustment for wear and steering damper. Steering wheel adjustable for rake
Rear axle: Single-joint low-pivot swing-axle and limited slip differential
Suspension: Self-leveling air suspension, telescopic shock absorbers adjustable while moving and torsion bar stabilisers front and rear

* In measuring gross H. P. power required for auxiliaries has not been taken into account.

** The stated HP figure which does take account of power required for auxiliaries is the net power available at the clutch. The manufacturers reserve the right to change specifications and equipment without notice.

Weights

Vehicle weight 5,820 lbs. = 2,640 kg

Permitted maximum weight

7,365 lbs. = 3,340 kg

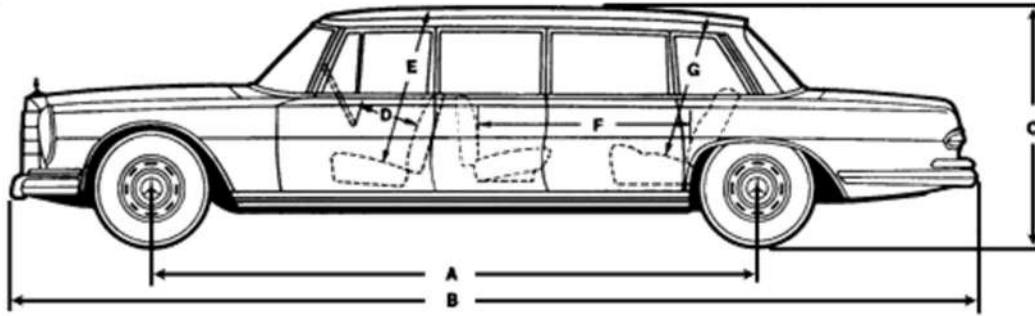

- A Wheel base 153.3 ins. = 3,900 mm
- B Overall length 246 ins. = 6,240 mm
- C Height 60 ins. = 1,500 mm + increase by 2.0 ins. = 50 mm
- D Steering wheel rim to backrest of driving seat 14.4 ins. = 365 mm
- E Seat to roof 38.2 ins. = 970 mm

- F Front edge rear backrest to front edge of vis-a-vis seat backrest 53.5 ins. = 1,360 mm
- G Rear seat to roof 34.9 ins. = 885 mm
- H Width measured at level of window key front 61.8 ins. = 1,570 mm rear 60.4 ins. = 1,535 mm
- K Overall width 76.8 ins. = 1,950 mm

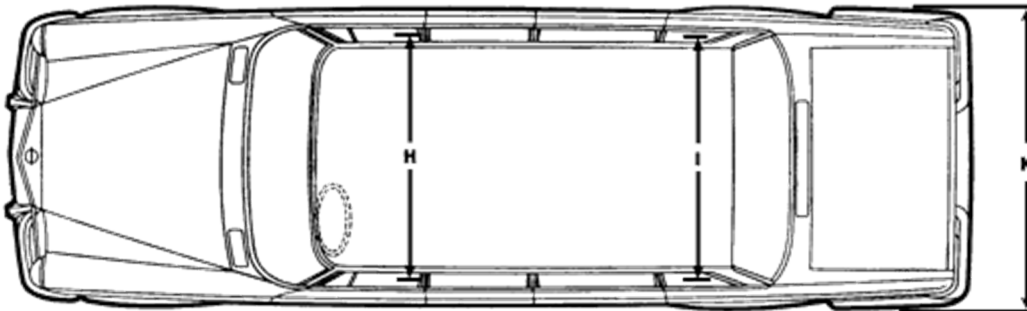

- Track front 62.53 ins. = 1,587 mm
- Track rear 62.24 ins. = 1,581 mm
- Usable luggage space 20.5 cu. ft. = 0.58 m³
- Road Clearance min./max. approx. 6/7.9 ins. = 152/200 mm
- Turning circle 47.8 ft. = 14.6 m
- Height with open hood 78.7 ins. = 2,000 mm
- Height with open trunk lid 64.6 ins. = 1,640 mm
- Width with open driver's door 112.6 ins. = 2,860 mm
- Angle of approach = 20o 30'
- Angle of departure = 9o 30'
- Ramp angle = 9o 30'

Basic Equipment

Windshield

Windshield washers
Two-speed wipers

Rear Window

Rear window electrically heated

Lighting

Asymmetric dim beam
Fog lamps
Front and rear limit lights
Flashing direction indicators
Parking light
Brake lights
Back-up lights
Instrument lights dimmer-switch controlled
Socket for inspection lamp (in the engine compartment)
Light in glove box
Map-reading light
Trunk light
Foot well lights, 2 in front and 2 at rear
Roof light at rear
2 adjustable reading lamps in rear roof pillars

Instruments

Speedometer
Tachometer
Indicator of selector lever position
Oil pressure gauge
Gasoline gauge
Engine thermometer
Indicator lights for battery charge, flashing indicators, headlight beam, servo hydraulic system, air pressure for suspension and brake booster, fuel reserve
Electric clock
Total-mileage recorder
Trip recorder
Outside-air thermometer
Pull button for level adjustment
Pull button for rear window heating

Miscellaneous

Console tray between front seats
Side compartments on all 4 doors
Parcel shelf in the front over transmission tunnel
Glow-free rear-view mirror
2 exterior rear-view mirrors adjustable from the inside

Signalling equipment

Air horn and two electric horns
Additional high-volume horn available
Automatic cancelling of flashing indicators

Locks

4 hydraulically-operated safety door-locks
Central control for locks on doors, trunk and gasoline-filler cap.
Manual operation of all door locks from the inside, and of front doors and trunk from outside
Steering lock combined with ignition switch, starter and device to prevent accidental starter operation
Lock on glove box

Hydraulic push-button system

Push-button hydraulic opening and closing of front and rear door windows and the central rear side windows
Rear seat and center arm-rest fully adjustable hydraulically by pressing a button
Hydraulic adjustment of shock-absorbers by lever on the steering column

Heating and Ventilating system

Front: Heating and ventilating system with 2 heat-exchangers and blower
Rear: Heating and ventilating system with 1 heat-exchanger and blower
Atmospheric pressure ventilation system
Temperature selector with electronic control to compensate for effect of different driving speeds
De-froster for side windows
De-frosting of rear window by electric heating elements embedded in the glass

Optional extras

Air conditioner, also for cooling the refreshment bar
Katacolor glass
Intercommunication system
driver-passenger compartment
Steel sliding roof hydraulically operated by push button

2 padded sun-visors, with vanity mirror on passenger side
6 hand-rails in the roof frame with coat-hangers in rear
Grab-handles on all doors
Armrests on all doors and beside facing seats
Independent center armrests for each of the front seats
Folding armrest in rear
2 adjustable headrests in rear
Ashtrays on all doors
Automatic cigar-lighter on all doors
Safety steering wheel adjustable for rake
2 footrests in rear
Curtains on rear window and rear side windows
Center partition with hydraulically-operated glass screen, bar and 2 shelves for vanity boxes. Lids over shelves serve as small tables for oddments.
2 single seats facing rear bench seat or in the 6-door version two folding seats in driving direction

Radio with autom. aerial, short wave adapter
Set of suitcases, etc.